

4HP-6-LT

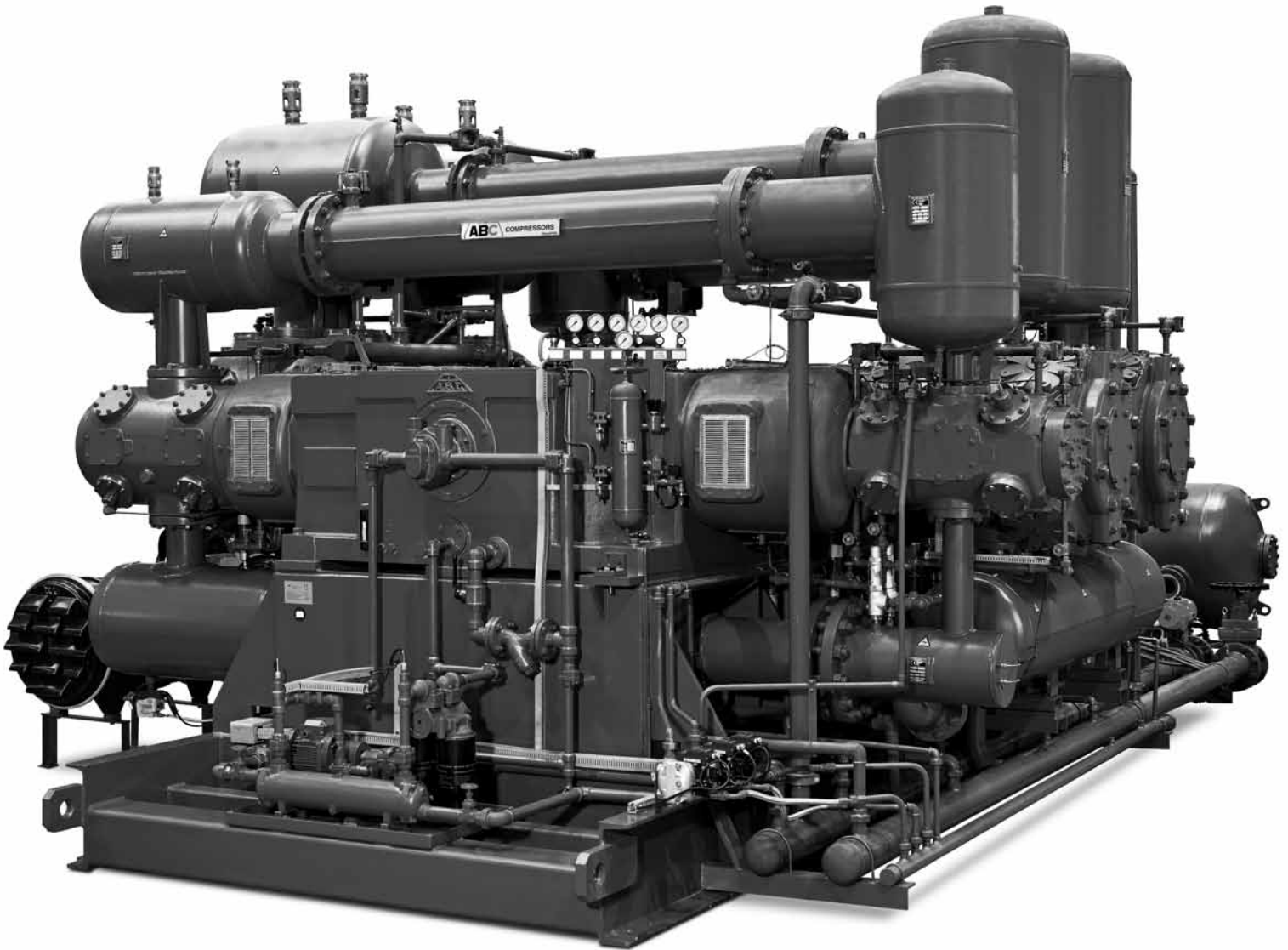

RELIABLE BEYOND LIMITS



PET APPLICATIONS

The new 4HP-6-LT model, of bigger size and capacity, completes a cycle of market-adapted powers and products. Therefore, it has become into the biggest alternative compressor of the PET market.

Our concerns regarding the excellence and the use of high technologies have gone hand in hand in order to produce an added value machine, with a perfect regulation and the best energy efficiency of the sector.

CAPACITY	EFFICIENCY	RELIABILITY
6.000 m³/h.	4 COMPRESSION STAGES PERFECT REGULATION	CONSTANT PERFORMANCE 8.000 hours
4HP-6-LT compressor, supplied with a 1.000kW motor , offers a 6.000m³/h flow , a rise of more than the 80% with respect to other big alternative machines of the market.	<p>Maximum energy efficiency:</p> <ul style="list-style-type: none"> • 4 compression stages, adapting perfectly to isothermal cycle. • Double effect cylinders. Low linear speed. • Direct coupling, with lower energy losses in transmission. • Perfect adaptation to frequency converters (regulation up to the 54% of its capacity). 	<p>ABC compressor of horizontal and opposed cylinders is perfectly balanced, avoiding vibrations.</p> <p>Its efficient design allows working at low temperatures, extending the durability of wearing parts.</p> <p>Thus, the 4HP-6-LT compressor runs more than 8.000 hours at full load, and no stop for maintenance is needed.</p>

RANGE	800kW	900kW	1.000kW
40 bar capacity (m ³ /h FAD)	4.903	5.404	6.004
RPM	490	540	600
Absorbed power (kW)	705	786	888
Installed power (kW)	800	900	1.000
Weight (Tn)	40	40	40
Coupling type	Direct	Direct	Direct

THE BIGGEST AND MOST EFFICIENT COMPRESSOR OF PET MARKET



PROCESS COMPRESSORS

The HP6 platform is ready to compress all kind of gases up to 6 stages of compression, reaching to pressures up to 170 bar, being a very interesting option for gas applications, such as petrochemical, cogeneration, waste and industrial gases treatment...

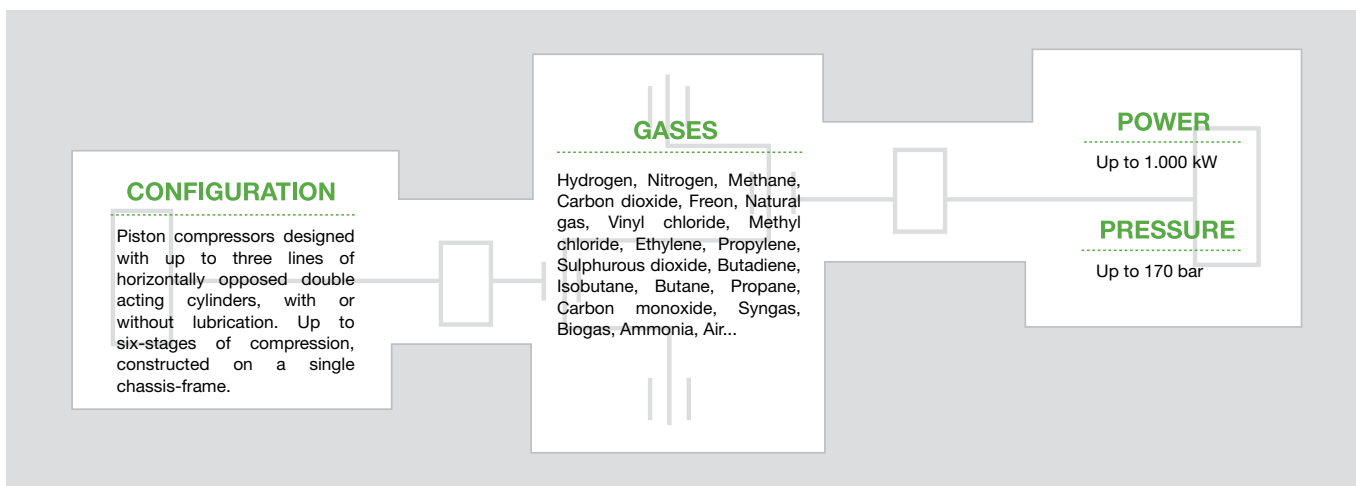

PETROCHEMICAL



WASTE TREATMENT



INDUSTRIAL GAS PRODUCERS



NATURAL GAS COGENERATION

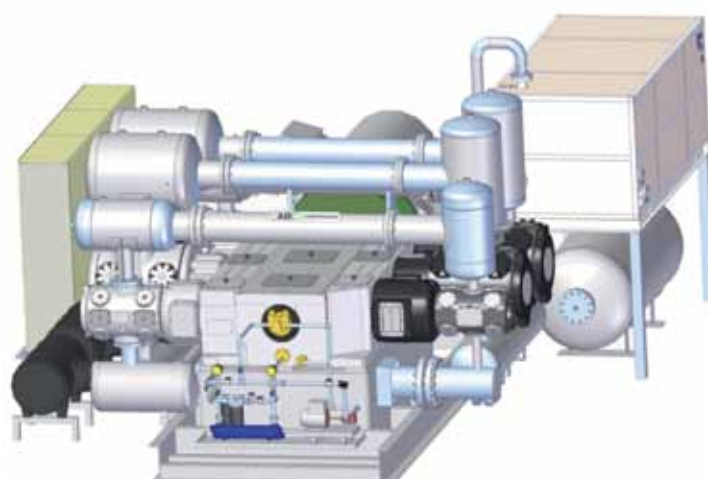

Depending on the space availability in the plant, compressor package (compressor, motor, dryer, receiver and electric cabinet) is supplied in different versions adapted to clients' requirements.

HEADQUARTER

Eibar

Polígono Azitain nº 6 P.O.Box 87
20600 EIBAR (Guipúzcoa) SPAIN

Tel.: +34 943 820 400

Fax: +34 943 820 235

abc@abc-compressors.com

Contact with our **INTERNATIONAL NETWORK**
through:

www.abc-compressors.com

RELIABLE BEYOND LIMITS



ARIZAGA, BASTARRICA Y CIA, S.A.